

Reference Data

| Reference Data | |
|---|-----|
| Power Calculations | 587 |
| Equations..... | 593 |
| Wattage Requirements..... | 595 |
| Tubular Elements and Assembly Selection Guide..... | 597 |



Reference Data

Power Calculations

Calculations for Required Heat Energy

The total heat energy (kWH or BTU) required to satisfy the system needs will be either of the two values shown below depending on which calculated result is larger.

A. Heat required for start up

B. Heat required to maintain the desired temperature

The power required (kW) will be the heat energy value (kWH) divided by the required start up or working cycle time. The kW rating of the heater will be the greater of these values plus a safety factor.

The calculation of start up and operating requirements consist of several distinct parts that are best handled separately. However, a short method can also be used for a quick estimate of heat energy required. Both methods are defined and then evaluated using the following formulas and methods:

Short Method

Start-up watts = A + C + %L + safety factor

Operating watts = B + D + L + safety factor

Safety factor is normally 10 to 35% based on application.

A = Watts required to raise the temperature of material and equipment to the operating point, within the time desired

B = Watts required to maintain temperature of the material during the working cycle

C = Watts required to melt or vaporize load material during start-up period

D = Watts required to melt or vaporize load material during working cycle

L = Watts lost from surfaces by:

- Conduction-use equation to the right
- Radiation-use heat loss curves
- Convection-use heat loss curves

Equation for A and B (Absorbed watts-raising temperature)

$$\frac{\text{lbs} \times C_p \times \text{°F}}{\text{hrs} \times 3.412}$$

- lbs = weight of material
- C_p = specific heat of material (BTU/lb x °F)
- °F = temperature rise
- hrs = start-up or cycle time

Equation for C and D (Absorbed watts-melting or vaporizing)

$$\frac{\text{lbs} \times \text{BTU/lb}}{\text{hrs} \times 3.412}$$

- lbs = weight of material
- BTU/lb = heat of fusion or vaporization
- hrs = start-up or cycle time

Equation for L (Lost conducted watts)

$$\frac{k \times \text{ft}^2 \times \text{°F}}{\text{in} \times 3.412}$$

- k = thermal conductivity (BTU x in./[ft² x °F x hr])
- ft² = surface area
- °F = temperature differential to ambient

Reference Data

Power Calculations

Conduction and Convection Heating

Absorbed Energy, Heat Required to Raise the Temperature of a Material

Because substances all heat differently, different amounts of heat are required in making a temperature change. The specific heat capacity of a substance is the quantity of heat needed to raise the temperature of a unit quantity of the substance by one degree. Calling the amount of heat added **Q**, which will cause a change in temperature ΔT to a weight of substance **W**, at a specific heat of material **C_p**, then $Q = w \times C_p \times \Delta T$.

Since all calculations are in watts, an additional conversion of 3.412 BTU = 1 Wh is introduced yielding:

Equation 1

$$Q_A \text{ or } Q_B = \frac{w \times C_p \times \Delta T}{3.412}$$

Q_A = heat required to raise temperature of materials during heat-up (Wh)

Q_B = heat required to raise temperature of materials processed in working cycle (Wh)

w = weight of material (lb)

C_p = specific heat of material (BTU/lb x °F)

ΔT = temperature rise of material ($T_{\text{Final}} - T_{\text{Initial}}$)(°F)

This equation should be applied to all materials absorbing heat in the application. Heated media, work being processed, vessels, racks, belts and ventilation air should be included.

Example: How much heat energy is needed to change the temperature of 50 lbs of copper from 10 to 70°F?

$$\begin{aligned} Q &= w \times C_p \times \Delta T \\ &= \frac{(50 \text{ lbs}) \times (0.10 \text{ BTU}/[\text{lb} \times \text{°F}]) \times (60\text{°F})}{3.412} = 88 \text{ (Wh)} \end{aligned}$$

Heat Required to Melt or Vaporize a Material

In considering adding heat to a substance, it is also necessary to anticipate changes in state that might occur during this heating such as melting and vaporizing. The heat needed to melt a material is known as the latent heat of fusion and represented by **H_f**. Another state change is involved in vaporization and condensation. The latent heat of vaporization **H_v** of the substance is the energy required to change a substance from a liquid to a vapor. This same amount of energy is released as the vapor condenses back to a liquid.

Equation 2

$$Q_C \text{ or } Q_D = \frac{w \times H_f}{3.412} \quad \text{OR} \quad \frac{w \times H_v}{3.412}$$

Q_C = heat required to melt/vaporize materials during heat-up (Wh)

Q_D = heat required to melt/vaporize materials processed in working cycle (Wh)

w = weight of material (lb)

H_f = latent heat of fusion (BTU/lb)

H_v = latent heat of vaporization (BTU/lb)

Example: How much energy is required to melt 50 lbs of lead?

$$\begin{aligned} Q &= w \times H_f \\ &= \frac{(50 \text{ lbs}) \times (9.8 \text{ BTU}/\text{lb})}{3.412 \text{ BTU}/(\text{Wh})} = 144 \text{ (Wh)} \end{aligned}$$

Changing state (melting and vaporizing) is a constant temperature process. The **C_p** value (from Equation 1) of a material also changes with a change in state. Separate calculations are thus required using Equation 1 for the material below and above the phase change temperature.

Reference Data

Power Calculations

Conduction and Convection Heating

Conduction Heat Losses

Heat transfer by conduction is the contact exchange of heat from one body at a higher temperature to another body at a lower temperature, or between portions of the same body at different temperatures.

Equation 3A—Heat Required to Replace Conduction Losses

$$Q_{L1} = \frac{k \times A \times \Delta T \times t_e}{3.412 \times L}$$

Q_{L1} = conduction heat losses (Wh)

k = thermal conductivity
(BTU x in./[ft² x °F x hour])

A = heat transfer surface area (ft²)

L = thickness of material (in.)

ΔT = temperature difference across material
($T_2 - T_1$) °F

t_e = exposure time (hr)

This expression can be used to calculate losses through insulated walls of containers or other plane surfaces where the temperature of both surfaces can be determined or estimated.

Convection Heat Losses

Convection is a special case of conduction. Convection is defined as the transfer of heat from a high temperature region in a gas or liquid as a result of movement of the masses of the fluid.

Equation 3B—Convection Losses

$$Q_{L2} = A \times F_{SL} \times C_F$$

Q_{L2} = convection heat losses (Wh)

A = surface area (in²)

F_{SL} = vertical surface convection loss factor
(W/in²) evaluated at surface temperature

C_F = surface orientation factor
heated surface faces up horizontally = 1.29
vertical = 1.00
heated surface faces down horizontally = 0.63

Radiation Heat Losses

Radiation losses are not dependent on orientation of the surface. Emissivity is used to adjust for a material's ability to radiate heat energy.

Equation 3C—Radiation Losses

$$Q_{L3} = A \times F_{SL} \times e$$

Q_{L3} = radiation heat losses (Wh)

A = surface area (in²)

F_{SL} = blackbody radiation loss factor at surface temperature (W/in²)

e = emissivity correction factor of material surface

Example:

We find that a blackbody radiator (perfect radiator) at 500°F, has heat losses of 2.5 W/in². Polished aluminum, in contrast, ($e = 0.09$) only has heat losses of 0.22 W/in² at the same temperature ($2.5 \text{ W/in}^2 \cdot 0.09 = 0.22 \text{ W/in}^2$).

Combined Convection and Radiation Heat Losses

Some curves combine both radiation and convection losses. This saves you from having to use both Equations 3B and 3C. If only the convection component is required, then the radiation component must be determined separately and subtracted from the combined curve.

Equation 3D—Combined Convection and Radiation Heat Losses

$$Q_{L4} = A \times F_{SL}$$

Q_{L4} = surface heat losses combined convection and radiation (Wh)

A = surface area (in²)

F_{SL} = combined surface loss factor at surface temperature (W/in²)

This equation assumes a constant surface temperature.

Reference Data

Power Calculations

Conduction and Convection Heating

Total Heat Losses

The total conduction, convection and radiation heat losses are summed together to allow for all losses in the power equations. Depending on the application, heat losses may make up only a small fraction of total power required or it may be the largest portion of the total. Therefore, do not ignore heat losses unless previous experience tells you it is alright to do.

Equation 3E—Total Losses

$Q_L = Q_{L1} + Q_{L2} + Q_{L3}$ If convection and radiation losses are calculated separately. (Surfaces are not uniformly insulated and losses must be calculated separately.)

OR

$Q_L = Q_{L1} + Q_{L4}$ If combined radiation and convection curves are used. (Pipes, ducts, uniformly insulated bodies.)

Start-Up and Operating Power Required

Both of these equations estimate required energy and convert it to power. Since power (watts) specifies an energy rate, we can use power to select electric heater requirements. Both the start-up power and the operating power must be analyzed before heater selection can take place.

Equation 4—Start-Up Power (Watts)

$$P_s = \left[\frac{Q_A + Q_C}{t_s} + \frac{2}{3} (Q_L) \right] \times (1 + \text{S.F.})$$

Q_A = heat absorbed by materials during heat-up (Wh)

Q_C = latent heat absorbed during heat-up (Wh)

Q_L = conduction, convection, radiation losses (Wh)

S.F. = safety factor

t_s = start-up (heat-up) time required (hr)

During start up of a system the losses are zero, and rise to 100% at process temperature. A good approximation of actual losses is obtained when heat losses (Q_L) are multiplied by $\frac{2}{3}$.

Equation 5—Operating Power (Watts)

$$P_o = \left[\frac{Q_B + Q_D}{t_c} + (Q_L) \right] \times (1 + \text{S.F.})$$

Q_B = heat absorbed by processed materials in working cycle (Wh)

Q_D = latent heat absorbed by materials heated in working cycle (Wh)

Q_L = conduction, convection, radiation losses (Wh)

S.F. = safety factor

t_c = cycle time required (hr)

Reference Data

Power Calculations

Conduction and Convection Heating

Radiant Heating

When the primary mode of heat transfer is radiation, we add a step after Equation 5.

Equation 6 is used to calculate the net radiant heat transfer between two bodies. We use this to calculate either the radiant heater temperature required or (if we know the heater temperature, but not the power required) the maximum power which can be transferred to the load.

Equation 6—Radiation Heat Transfer Between Infinite Size Parallel Surfaces

$$\frac{P_R}{A} = \frac{S (T_1^4 - T_2^4) \left(\frac{1}{e_f} \right) F}{(144 \text{ in}^2/\text{ft}^2) (3.412 \text{ BTU/Wh})}$$

P_R = power absorbed by the load (watts) - from equation 4 or 5

A = area of heater (in²) - known or assumed

S = Stephan Boltzman constant
= $0.1714 \cdot 10^{-8}$ (BTU/hr. sq. ft. °R⁴)

T_1 (°R) = emitter temperature (°F + 460)

T_2 (°R) = load temperature (°F + 460)

e_f = emissivity correction factor - see Emissivity Correction Factor information to the right

F = shape factor (0 to 1.0) - see Shape Factor for Radiant Application graph to the right

Emissivity Correction Factor (e_f)

$$e_f = \frac{1}{e_S} + \frac{1}{e_L} - 1 \quad \text{plane surfaces}$$

$$e_f = \frac{1}{e_S} + \frac{D_S}{D_L} \left(\frac{1}{e_L} - 1 \right) \quad \text{concentric cylinders inner radiating outward}$$

$$e_f = \frac{1}{e_S} + \left(\frac{D_S}{D_L} \times \frac{1}{e_L} \right) - 1 \quad \text{concentric cylinders outer radiating inward}$$

e_S = heater emissivity (from material emissivity tables)

e_L = load emissivity (from material emissivity tables)

D_S = heater diameter

D_L = load diameter

Shape Factor for Radiant Application

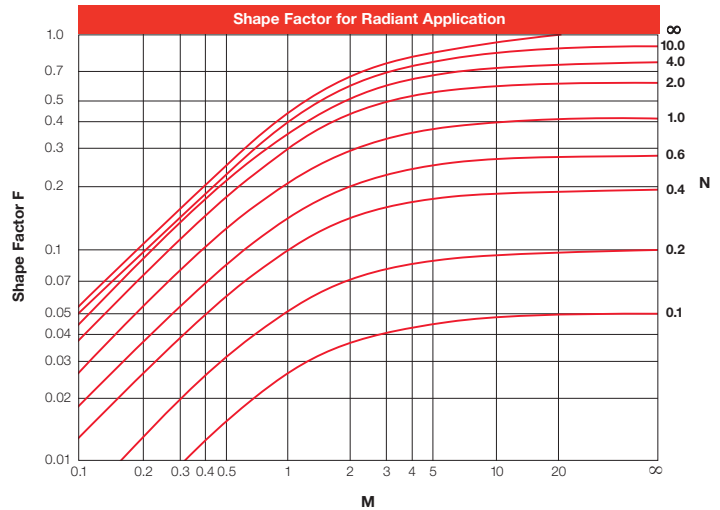

For Two Facing Panels:

$$N = \left(\frac{\text{Heated Length}}{\text{Distance to Material}} \right)$$

$$M = \left(\frac{\text{Heated Width}}{\text{Distance to Material}} \right)$$

Reference Data

Power Calculations

Conduction and Convection Heating

Power Evaluation

After calculating the start up and operating power requirements, a comparison must be made and various options evaluated.

Shown in the graph below are the start up and operating watts displayed in a graphic format to help you see how power requirements add up.

With this graphic aid in mind, the following evaluations are possible:

- Compare start up watts to operating watts.
- Evaluate effects of lengthening start-up time such that start-up watts equals operating watts (use timer to start system before shift).

- Recognize that more heating capacity exists than is being utilized. (A short start-up time requirement needs more wattage than the process in wattage.)
- Identify where most energy is going and redesign or add insulation to reduce wattage requirements.

Having considered the entire system, a reevaluation of start-up time, production capacity and insulating methods should be made.

Comparison of Start Up and Operating Power Requirements

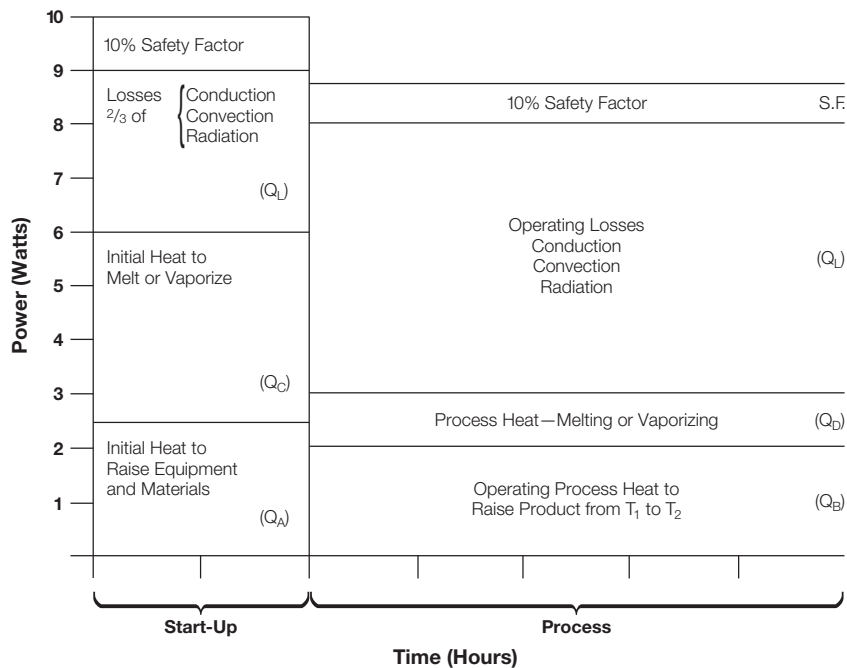

Reference Data

Equations

Ohm's Law

Volts

$$\text{Volts} = \sqrt{\text{Watts} \times \text{Ohms}}$$

$$\text{Volts} = \frac{\text{Watts}}{\text{Amperes}}$$

$$\text{Volts} = \text{Amperes} \times \text{Ohms}$$

Ohms

$$\text{Ohms} = \frac{\text{Volts}}{\text{Amperes}}$$

$$\text{Ohms} = \frac{\text{Volts}^2}{\text{Watts}}$$

$$\text{Ohms} = \frac{\text{Watts}}{\text{Amperes}^2}$$

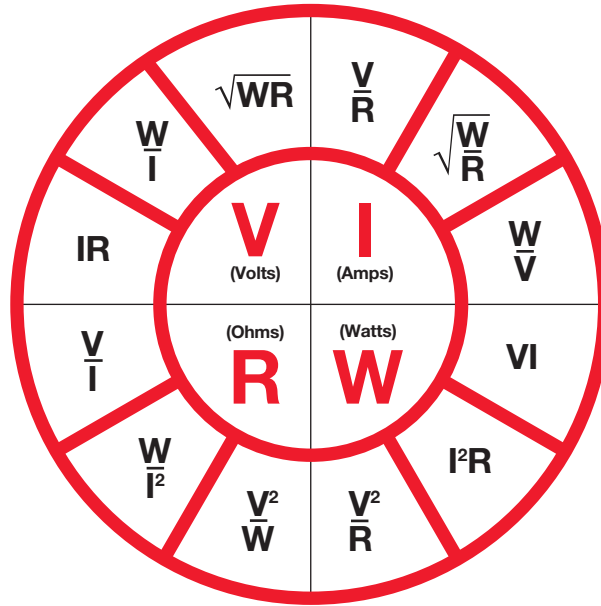

Amperes

$$\text{Amperes} = \frac{\text{Volts}}{\text{Ohms}}$$

$$\text{Amperes} = \frac{\text{Watts}}{\text{Volts}}$$

$$\text{Amperes} = \sqrt{\frac{\text{Watts}}{\text{Ohms}}}$$

Watts

$$\text{Watts} = \frac{\text{Volts}^2}{\text{Ohms}}$$

$$\text{Watts} = \text{Amperes}^2 \times \text{Ohms}$$

$$\text{Watts} = \text{Volts} \times \text{Amperes}$$

Wattage varies directly as ratio of voltages squared

$$W_2 = W_1 \times \left(\frac{V_2}{V_1}\right)^2$$

$$3 \text{ Phase Amperes} = \frac{\text{Total Watts}}{\text{Volts} \times 1.732}$$

Reference Data

Equations

Typical 3-Phase Wiring Diagrams and Equations for Resistive Heaters

Definitions

For Both Wye and Delta (Balanced Loads)

V_P = Phase voltage

V_L = Line voltage

I_P = Phase current

I_L = Line current

$R = R_1 = R_2 = R_3 =$
Resistance of each branch

W = Wattage

Wye and Delta Equivalents

$$W_{\text{DELTA}} = 3 W_{\text{WYE}}$$

$$W_{\text{ODELTA}} = \frac{2}{3} W_{\text{DELTA}}$$

$$W_{\text{OWYE}} = \frac{1}{2} W_{\text{WYE}}$$

3-Phase Delta (Balanced Load)

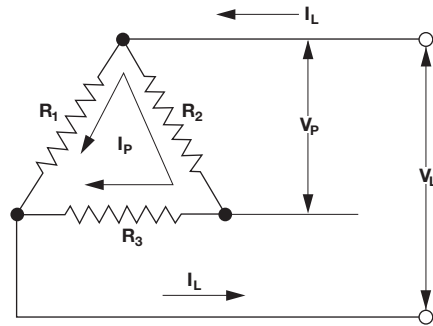

Equations For Delta Only

$$I_P = I_L / 1.73$$

$$V_P = V_L$$

$$W_{\text{DELTA}} = 3(V_L^2/R)$$

$$W_{\text{DELTA}} = 1.73 V_L I_L$$

3-Phase Wye (Balanced Load)

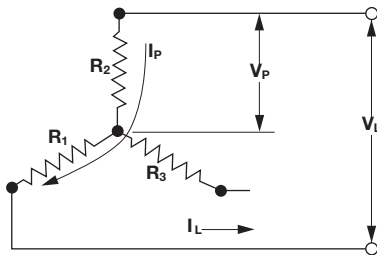

Equations For Wye Only

$$I_P = I_L$$

$$V_P = V_L / 1.73$$

$$W_{\text{WYE}} = V_L^2 / R = 3(V_P^2) / R$$

$$W_{\text{WYE}} = 1.73 V_L I_L$$

3-Phase Open Delta

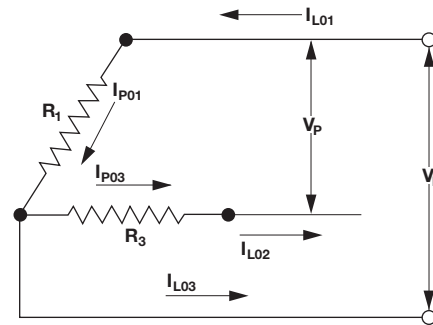

Equations For Open Delta Only

$$V_P = V_L$$

$$I_{P01} = I_{P03} = I_{L02}$$

$$I_{L03} = 1.73 I_{P01}$$

$$W_{\text{ODELTA}} = 2(V_L^2/R)$$

3-Phase Open Wye (No Neutral)

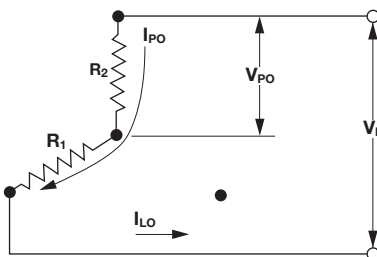

Equations For Open Wye Only

$$I_{PO} = I_{LO}$$

$$V_{PO} = V_L / 2$$

$$W_{\text{OWYE}} = \frac{1}{2} (V_L^2/R)$$

$$W_{\text{OWYE}} = 2 (V_{PO}^2/R)$$

$$W_{\text{OWYE}} = V_L I_{LO}$$

Reference Data

Wattage Requirements

The following equations can be used to make quick estimates of wattage requirements.

For Steel

Use equation:

$$kW = \frac{\text{kilograms} \times \text{temperature rise } (^{\circ}\text{C})}{5040 \times \text{heat-up time (hrs.)}}$$

OR

$$kW = \frac{\text{pounds} \times \text{temperature rise } (^{\circ}\text{F})}{20,000 \times \text{heat-up time (hrs.)}}$$

For Oil

Use equation:

$$kW = \frac{\text{gallons} \times \text{temperature rise } (^{\circ}\text{F})}{800 \times \text{heat-up time (hrs.)}}$$

OR

$$kW = \frac{\text{liters} \times \text{temperature rise } (^{\circ}\text{C})}{1680 \times \text{heat-up time (hrs.)}}$$

1 cu. ft. = 7.49 gallons

For Heating Water in Tanks

Use equation:

$$kW = \frac{\text{gallons} \times \text{temperature rise } (^{\circ}\text{F})}{375 \times \text{heat-up time (hrs.)}}$$

OR

$$kW = \frac{\text{liters} \times \text{temperature rise } (^{\circ}\text{C})}{790 \times \text{heat-up time (hrs.)}}$$

1 cu. ft. = 7.49 gallons

For Heating Flowing Water

Use equation:

$$kW = \text{GPM}^* \times \text{temperature rise } (^{\circ}\text{F}) \times 0.16$$

OR

$$kW = \text{liters/min.} \times \text{temperature rise } (^{\circ}\text{C}) \times 0.076$$

For Air

Use equation:

$$kW = \frac{\text{CFM}^{**\textcircled{1}} \times \text{temperature rise } (^{\circ}\text{F})}{3000}$$

OR

$$kW = \frac{\text{cubic meters/min}^{\textcircled{1}} \times \text{temperature rise } (^{\circ}\text{C})}{47}$$

For Compressed Air

Use equation:

$$kW = \frac{\text{CFM}^{**\textcircled{2}} \times \text{density}^{\textcircled{2}} \times \text{temperature rise } (^{\circ}\text{F})}{228}$$

OR

$$kW = \frac{\text{cubic meters/min}^{\textcircled{2}} \times \text{temperature rise } (^{\circ}\text{C}) \times \text{density (kg/m}^3\text{)}^{\textcircled{2}}}{57.5}$$

* Gallons per minute

** Cubic feet per minute

^① Measured at normal temperature and pressure

^② Measured at heater system inlet temperature and pressure

Reference Data

Wattage Requirements

Kilowatt-Hours to Superheat Steam

1. Plot points on lines **P**, **Q** and **S**. **P** represents the inlet temperature (and saturation pressure) of the system.
Q represents the liquid content of the water vapor.
S indicates the outlet temperature minus the saturated temperature.
W indicates the heat content of the water vapor.
 2. Draw a straight line from **P** through **Q** to **W**. Read **W₁**.
 3. Draw a straight line from **P** through **S** to **W**. Read **W₂**.
 4. Required watts = Weight (lbs.) of steam/hour x (W₂-W₁)
- Watt density is critical. Review temperature and velocity prior to heater selection.
Reference is 80 percent quality at 20 psig.

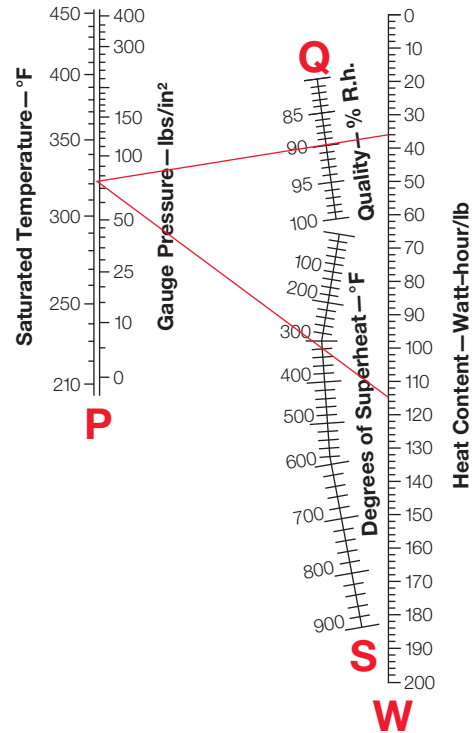

Reference Data

Tubular Elements and Assembly Selection Guide

Watlow® tubular elements and assemblies are primarily used for direct immersion in water, oils, viscous materials, solvents, process solutions and molten materials as well as air and gases.

Additionally, round and flat surface tubular elements (WATROD and FIREBAR® heaters respectively) can be used for surface heating.

WATROD and FIREBAR heating elements may be purchased separately, or fabricated into process heating assemblies, including:

- Screw plug
- Flange
- Circulation
- Booster
- Engine preheater
- Over-the-side
- Vertical loop
- Drum
- Duct

Both elements and assemblies are available from stock. They can be configured with a variety of watt and volt ratings, terminations, sheath materials and mounting options to satisfy the most demanding applications.

If our stock products do not meet your application needs, Watlow can custom engineer the optimum heater.

Performance Capabilities

- Sheath temperatures up to 1800°F (983°C)
- Assembly wattages to 3 megawatts
- Process assembly ratings up to 3000psi
- Watt densities up to 120 W/in² (18.6 W/cm²)
- Enhanced performance beyond these specifications is available upon request
- Watlow can design thermal systems to meet specific performance criteria. Contact your local Watlow representative for assistance.



Features and Benefits

51 standard bend formations

- Enables designing of the heating element around available space to maximize heating efficiency

FIREBAR flat surface geometry

- Enhances heat transfer in both immersion and air applications and also surface heating
- Increases surface area per linear inch allowing heaters to run cooler in viscous materials

Wattages from 95 watts to 3 megawatts (on individual elements and assemblies respectively)

- Makes tubular heaters one of the most versatile electric heating sources available

Typical Applications

- Liquids
- Air
- Gases
- Molten materials
- Contact surface heating
- Radiant surface heating

Reference Data

Tubular Elements and Assembly Selection Guide

The following two charts will help you select an appropriate heater based on your application and watt density restrictions. These charts are application driven. The total wattage required by your application should be known before selecting a specific heater type(s) from the stock tables. If your required wattage is not known, please contact your Watlow representative.

Once the heater type has been identified, turn to the appropriate product section for information on the element or assembly.

Element and Assembly Selection Guide

To identify the tubular heater type best suited to your application, consult the *Element and Assembly Selection Guide*.

In most cases Watlow recommends using single tubular heating elements for low kilowatt applications.

Assemblies are better suited for large kilowatt applications to heat liquids, air or gases.

When selecting a heater according to watt density, be sure to consider the following:

- Liquid viscosity at start up and at process temperature
- Operating temperature
- Chemical composition

Under the “**Heating Method**” column in the *Element and Assembly Selection Guide* locate the method that applies to your application to find the recommended “Heater Type.”

After identifying the heater type(s) suitable for your application, refer to the *Supplemental Applications Chart* for further application data. This chart will assist you in selecting the appropriate watt density and sheath material for your specific application. It also presents the performance characteristics for both WATROD and FIREBAR elements.

Element and Assembly Selection Guide

| Application | Heating Method | Heater Type |
|---|--|---|
| Liquids: | | |
| Acids | Direct immersion (circulating/non-circulating) | FIREBAR, WATROD, screw plug, flange, over-the-side, vertical loop, and pipe insert |
| Caustic soda 12% concentrate 10% concentrate 75% concentrate | Direct immersion (circulating/non-circulating) | WATROD, screw plug, square flange, flange, over-the-side, vertical loop, circulation, and pipe insert |
| Degreasing solutions | Direct immersion (circulating/non-circulating) | FIREBAR, WATROD, screw plug, square flange, flange, over-the-side, and pipe insert |
| Electroplating | Direct immersion (circulating/non-circulating) | FIREBAR, WATROD, screw plug, square flange, flange, over-the-side, drum, vertical loop and pipe insert |
| Ethylene glycol 50% concentrate 100% concentrate | Direct immersion (circulating/non-circulating) | FIREBAR, WATROD, screw plug, flange, over-the-side, circulation, booster, and engine preheater |
| Oils Asphalt Fuel oils Light grades 1 and 2 Medium grades 4 and 5 Heavy grade 6 and Bunker C Heat transfer Lubricating SAE 10, 20, 30 SAE 40, 50 API STD 614 Vegetable (cooking) | Direct immersion (circulating/non-circulating) | FIREBAR, WATROD, screw plug, square flange, flange, over-the-side, drum, vertical loop, circulation, booster, and pipe insert |
| Paraffin or wax | Direct immersion (circulating/non-circulating) | FIREBAR, WATROD, screw plug, square flange, flange, over-the-side, drum, and pipe insert |

CONTINUED

Reference Data

Tubular Elements and Assembly Selection Guide

Element and Assembly Selection Guide (Continued)

| Application | Heating Method | Heater Type |
|---|--|---|
| Water Clean Deionized DeminerIALIZED Potable Process | Direct immersion (circulating/non-circulating) | FIREBAR (non-process water only) WATROD, screw plug, screw plug with control assembly, square flange, flange, over-the-side, drum, vertical loop, circulation, booster, engine preheater and pipe insert |
| Air: | Direct (forced or natural convection) | FIREBAR, WATROD, FINBAR, WATROD enclosure heater, screw plug, flange, circulation, and duct |
| Gas: Hydrocarbons, Nitrogen, Oxygen Ozone, Steam | Direct (forced) | FIREBAR, WATROD, screw plug, flange, and circulation |
| Molten Materials: Aluminum Lead Salt Solder | Indirect (radiant) Direct (non-circulating) Direct (non-circulating) Direct (non-circulating) | WATROD FIREBAR and WATROD FIREBAR and WATROD FIREBAR and WATROD |
| Surface Heating: Dies, griddles, molds, platens | Direct | FIREBAR and WATROD |

Supplemental Applications Chart

This *Supplemental Applications Chart* is provided in addition to the *Element and Assembly Selection Guide*. This chart will help you select watt density and sheath materials for either WATROD or FIREBAR heating elements according to the specific media being heated.

For example, if you are heating vegetable oil, either WATROD or FIREBAR elements at 30 and 40 W/in² respectively (4.6 and 6.2 W/cm²) with 304 stainless steel, sheath can be used.

Supplemental Applications Chart

| Heated Material | Max. Operating Temperature °F (°C) | | WATROD Element | | FIREBAR Element | | Sheath Material |
|------------------------------|---------------------------------------|-------|---|-----------------|---|-----------------|-----------------|
| | | | Max. Watt Density W/in ² (W/cm ²) | Sheath Material | Max. Watt Density W/in ² (W/cm ²) | Sheath Material | |
| Acid Solutions (Mild) | | | | | | | |
| Acetic | 180 | (82) | 40 (6.2) | 316 SS | 40 (6.2) | | Incoloy® 800 |
| Boric (30% max.) | 257 | (125) | 40 (6.2) | Titanium | 40 (6.2) | | 304 SS |
| Carbonic | 180 | (82) | 40 (6.2) | Inconel® 600 | 40 (6.2) | | 304 SS |
| Chromic | 180 | (82) | 40 (6.2) | Titanium | N/A | N/A | N/A |
| Citric | 180 | (82) | 23 (3.6) | Incoloy® | 30 (4.6) | | Incoloy® 800 |
| Fatty Acids | 150 | (65) | 20 (3.1) | 316 SS | 30 (4.6) | | Incoloy® 800 |
| Lactic | 122 | (50) | 10 (1.6) | 316 SS | N/A | N/A | N/A |
| Levulinic | 180 | (82) | 40 (6.2) | Inconel® 600 | 40 (6.2) | | 304 SS |
| Malic | 122 | (50) | 10 (1.6) | 316 SS | 16 (2.5) | | Incoloy® 800 |
| Nitric (30% max.) | 167 | (75) | 20 (3.1) | 316 SS | 30 (4.6) | | Incoloy® 800 |
| Phenol—2-4 | | | | | | | |
| Disulfonic | 180 | (82) | 40 (6.2) | 316 SS | 40 (6.2) | | Incoloy® 800 |
| Phosphoric | 180 | (82) | 23 (3.6) | Incoloy® | 30 (4.6) | | Incoloy® 800 |
| Phosphoric (Aerated) | 180 | (82) | 23 (3.6) | 304 SS | 30 (4.6) | | 304 SS |

CONTINUED

Reference Data

Tubular Elements and Assembly Selection Guide

Supplemental Applications Chart (Continued)

| Heated Material | Max. Operating Temperature °F (°C) | | WATROD Element | | FIREBAR Element | | | |
|----------------------------|---------------------------------------|----------|---|-----------------|---|-----------------|-------------|----------------|
| | | | Max. Watt Density W/in ² (W/cm ²) | Sheath Material | Max. Watt Density W/in ² (W/cm ²) | Sheath Material | | |
| Proponic (10% max.) | 180 | (82) | 40 | (6.2) | Copper | 40 | (6.2) | 304 SS |
| Tannic | 167/180 | (75/82) | 23/40 | (3.6/6.2) | Steel/304 SS | 40 | (6.2) | 304 SS |
| Tartaric | 180 | (82) | 40 | (6.2) | 316 SS | 40 | (6.2) | Incoloy® 800 |
| Acetaldehyde | 180 | (82) | 10 | (1.6) | Copper | 16 | (2.4) | Incoloy® 800 |
| Acetone | 130 | (54) | 10 | (1.6) | 304 SS | 16 | (2.4) | 304 SS |
| Air | ① | ① | ① | ① | Incoloy® | ① | ① | Incoloy® 800 |
| Alcyl alcohol | 200 | (93) | 10 | (1.6) | Copper | 16 | (2.4) | Incoloy® 800 |
| Alkaline solutions | 212 | (100) | 40 | (6.2) | Steel | 48 | (7.4) | 304 SS |
| Aluminum acetate | 122 | (50) | 10 | (1.6) | 316 SS | 16 | (2.5) | Incoloy® 800 |
| Aluminum potassium sulfate | 212 | (100) | 40 | (6.2) | Copper | N/A | N/A | N/A |
| Ammonia gas | ① | ① | ① | ① | Steel | ① | ① | 304 SS |
| Ammonium acetate | 167 | (75) | 23 | (3.6) | Incoloy® | 30 | (4.6) | Incoloy® 800 |
| Amyl acetate | 240 | (115) | 23 | (3.6) | Incoloy® | 30 | (4.6) | Incoloy® 800 |
| Amyl alcohol | 212 | (100) | 20 | (3.1) | 304 SS | 30 | (4.6) | 304 SS |
| Aniline | 350 | (176) | 23 | (3.6) | 304 SS | 30 | (4.6) | 304 SS |
| Asphalt | 200-500 | (93-260) | 4-10 | (0.6 - 1.6) | Steel | 6-12 | (0.9 - 1.8) | 304 SS |
| Barium hydroxide | 212 | (100) | 40 | (6.2) | 316 SS | 40 | (6.2) | Incoloy® 800 |
| Benzene, liquid | 150 | (65) | 10 | (1.6) | Copper | 16 | (2.5) | 304 SS |
| Butyl acetate | 225 | (107) | 10 | (1.6) | 316 SS | 16 | (2.5) | Incoloy® 800 |
| Calcium bisulfate | 400 | (204) | 20 | (3.1) | 316 SS | N/A | N/A | N/A |
| Calcium chloride | 200 | (93) | 5-8 | (0.8 - 1.2) | Inconel® 600 | N/A | N/A | N/A |
| Carbon monoxide | — | — | ① | ① | Incoloy® | ① | ① | Incoloy® |
| Carbon tetrachloride | 160 | (71) | 23 | (3.6) | Incoloy® | 30 | (4.6) | Incoloy® |
| Caustic soda: | | | | | | | | |
| 2% | 210 | (98) | 48 | (7.4) | Incoloy® | — | — | Contact Watlow |
| 10% concentrate | 210 | (98) | 23 | (3.6) | Incoloy® | — | — | Contact Watlow |
| 75% | 180 | (82) | 23 | (3.6) | Incoloy® | — | — | Contact Watlow |
| Citric juices | 185 | (85) | 23 | (3.6) | Incoloy® | 30 | (4.6) | Incoloy® |
| Degreasing solution | 275 | (135) | 23 | (3.6) | Steel | 30 | (4.6) | 304 SS |
| Dextrose | 212 | (100) | 20 | (3.1) | 304 SS | 30 | (4.6) | 304 SS |
| Dyes and pigments | 212 | (100) | 23 | (3.6) | 304 SS | 30 | (4.6) | 304 SS |

Electroplating Baths:

| | | | | | | | | |
|-------------------|-----|-------|-----|-------------|--------|-----|-------|--------|
| Cadmium | 180 | (82) | 40 | (6.2) | 304 SS | 40 | (6.2) | 304 SS |
| Copper | 180 | (82) | 40 | (6.2) | 316 SS | N/A | N/A | N/A |
| Dilute cyanide | 180 | (82) | 40 | (6.2) | 316 SS | N/A | N/A | N/A |
| Rochelle cyanide | 180 | (82) | 40 | (6.2) | 316 SS | N/A | N/A | N/A |
| Sodium cyanide | 180 | (82) | 40 | (6.2) | 316 SS | N/A | N/A | N/A |
| Potassium cyanide | 180 | (82) | 40 | (6.2) | 316 SS | 40 | (6.2) | 304 SS |
| Ethylene glycol | 300 | (148) | 30 | (4.6) | Steel | 40 | (6.2) | 304 SS |
| Formaldehyde | 180 | (82) | 10 | (1.6) | 304 SS | 16 | (2.5) | 304 SS |
| Freon® gas | 300 | (148) | 2-5 | (0.3 - 0.8) | Steel | ① | ① | 304 SS |
| Gasoline | 300 | (148) | 23 | (3.6) | Steel | 30 | (4.6) | 304 SS |

CONTINUED

① Contact your Watlow representative.

Reference Data

Tubular Elements and Assembly Selection Guide

Supplemental Applications Chart (Continued)

| Heated Material | Max. Operating Temperature °F (°C) | | WATROD Element | | | FIREBAR Element | | |
|--------------------|---------------------------------------|-----------|---|-------------|------------------------|---|-------------|-----------------|
| | | | Max. Watt Density W/in ² (W/cm ²) | | Sheath Material | Max. Watt Density W/in ² (W/cm ²) | | Sheath Material |
| Gelatin liquid | 150 | (65) | 23 | (3.6) | | 304 SS | 30 | |
| Gelatin solid | 150 | (65) | 5 | (0.8) | 304 SS | 7 | (1.0) | 304 SS |
| Glycerin | 500 | (260) | 10 | (1.6) | Incoloy® | 12 | (1.9) | 304 SS |
| Glycerol | 212 | (100) | 23 | (3.6) | Incoloy® | 30 | (4.6) | 304 SS |
| Grease: | | | | | | | | |
| Liquid | — | — | 23 | (3.6) | Steel | 30 | (4.6) | 304 SS |
| Solid | — | — | 5 | (0.8) | Steel | 7 | (1.0) | 304 SS |
| Hydrazine | 212 | (100) | 16 | (2.5) | 304 SS | 20 | (3.1) | 304 SS |
| Hydrogen | ① | ① | — | — | Incoloy® | ① | ① | Incoloy® 800 |
| Hydrogen chloride | ① | ① | — | — | Inconel® 600 | ① | ① | N/A |
| Hydrogen sulfide | ① | ① | — | — | 316 SS (heavy wall) | ① | ① | N/A |
| Magnesium chloride | 212 | (100) | 40 | (6.2) | Inconel® 600 | 40 | (6.2) | Incoloy® 800 |
| Magnesium sulfate | 212 | (100) | 40 | (6.2) | 304 SS | 40 | (6.2) | 304 SS |
| Magnesium sulfate | 212 | (100) | 40 | (6.2) | 316 SS | 40 | (6.2) | 304 SS |
| Methanol gas | ① | ① | — | — | 304 SS | ① | ① | 304 SS |
| Methylamine | 180 | (82) | 20 | (3.1) | Inconel® 600 | 30 | (4.6) | 304 SS |
| Methylchloride | 180 | (82) | 20 | (3.1) | Copper | N/A | N/A | N/A |
| Molasses | 100 | (37) | 4-5 | (0.6 - 0.8) | 304 SS | 5-8 | (0.8 - 1.2) | 304 SS |
| Molten salt bath | 800-900 | (426-482) | 25-30 | (3.8 - 4.6) | Monel® | N/A | N/A | N/A |
| Naphtha | 212 | (100) | 10 | (1.6) | Steel | 16 | (2.5) | 304 SS |

Oils

| | | | | | | | | |
|-------------------------------------|-----|-------|----|-------|-------|----|-------|--------|
| Fuel oils: | | | | | | | | |
| Grades 1 and 2 (distillate) | 200 | (93) | 23 | (3.6) | Steel | 30 | (4.6) | 304 SS |
| Grades 4 and 5 (residual) | 200 | (93) | 13 | (2.0) | Steel | 16 | (2.5) | 304 SS |
| Grades 6 and Bunker C (residual) | 160 | (71) | 8 | (1.2) | Steel | 10 | (1.6) | 304 SS |
| Heat transfer oils: ② | | | | | | | | |
| Static | 500 | (260) | 16 | (2.5) | Steel | 23 | (3.6) | 304 SS |
| | 600 | (315) | 10 | (1.6) | Steel | 16 | (2.5) | 304 SS |
| Circulating | 500 | (260) | 23 | (3.6) | Steel | 30 | (4.6) | 304 SS |
| | 600 | (315) | 15 | (2.3) | Steel | 20 | (3.1) | 304 SS |
| Lubrication oils: | | | | | | | | |
| SAE 10, 90-100 SSU @ 130°F | 250 | (121) | 23 | (3.6) | Steel | 30 | (4.6) | 304 SS |
| SAE 20, 120-185 SSU @ 130°F | 250 | (121) | 23 | (3.6) | Steel | 30 | (4.6) | 304 SS |
| SAE 30, 185-255 SSU @ 130°F | 250 | (121) | 23 | (3.6) | Steel | 30 | (4.6) | 304 SS |
| SAE 40, -80 SSU @ 210°F | 250 | (121) | 13 | (2.0) | Steel | 18 | (2.7) | 304 SS |
| SAE 50, 80-105 SSU @ 210°F | 250 | (121) | 13 | (2.0) | Steel | 18 | (2.7) | 304 SS |

CONTINUED

① Contact your Watlow representative.

② Maximum operating temperatures and watt densities are detailed in *Heat Transfer Oil* charts on page 604.

Reference Data

Tubular Elements and Assembly Selection Guide

Supplemental Applications Chart (Continued)

| Heated Material | Max. Operating Temperature °F (°C) | | WATROD Element | | FIREBAR Element | | | |
|--------------------------|---------------------------------------|-------|---|-----------------|---|-----------------|-------|--------------|
| | | | Max. Watt Density W/in ² (W/cm ²) | Sheath Material | Max. Watt Density W/in ² (W/cm ²) | Sheath Material | | |
| Miscellaneous oils: | | | | | | | | |
| Draw bath | 600 | (315) | 23 | (3.6) | Steel | 30 | (4.6) | 304 SS |
| Hydraulic | — | — | 15 ^③ | (2.3) | Steel | 15 ^③ | (2.3) | 304 SS |
| Linseed | 150 | (65) | 50 | (7.7) | Steel | 60 | (9.3) | 304 SS |
| Mineral | 200 | (93) | 23 | (3.6) | Steel | 30 | (4.6) | 304 SS |
| | 400 | (204) | 16 | (2.5) | Steel | 23 | (3.6) | 304 SS |
| Vegetable/shortening | 400 | (204) | 30 | (4.6) | 304 SS | 40 | (6.2) | 304 SS |
| Paraffin or wax (liquid) | 150 | (65) | 16 | (2.4) | Steel | 20 | (3.1) | 304 SS |
| Perchloroethylene | 200 | (93) | 23 | (3.6) | Steel | 30 | (4.6) | 304 SS |
| Potassium chlorate | 212 | (100) | 40 | (6.2) | 316 SS | N/A | N/A | N/A |
| Potassium chloride | 212 | (100) | 40 | (6.2) | 316 SS | N/A | N/A | N/A |
| Potassium hydroxide | 160 | (71) | 23 | (3.6) | Monel® | N/A | N/A | N/A |
| Soap, liquid | 212 | (100) | 20 | (3.1) | 304 SS | 30 | (4.6) | 304 SS |
| Sodium acetate | 212 | (100) | 40 | (6.2) | Steel | 50 | (7.7) | 304 SS |
| Sodium cyanide | 140 | (60) | 40 | (6.2) | Incoloy® | 50 | (7.7) | Incoloy® 800 |
| Sodium hydride | 720 | (382) | 28 | (4.3) | Incoloy® | 36 | (5.5) | Incoloy® 800 |
| Sodium hydroxide | — | — | — | — | See Caustic Soda | — | — | — |
| Sodium phosphate | 212 | (100) | 40 | (6.2) | Copper | 50 | (7.7) | 304 SS |
| Steam, flowing | 300 | (148) | 10 | (1.6) | Incoloy® | ① | ① | Incoloy® 800 |
| | 500 | (260) | 5-10 | (0.8-1.6) | Incoloy® | ① | ① | Incoloy® 800 |
| | 700 | (371) | 5 | (0.8) | Incoloy® | ① | ① | Incoloy® 800 |
| Sulfur, molten | 600 | (315) | 10 | (1.6) | Incoloy® | 12 | (1.8) | Incoloy® 800 |
| Toluene | 212 | (100) | 23 | (3.6) | Steel | 30 | (4.6) | 304 SS |
| Trichlorethylene | 150 | (65) | 23 | (3.6) | Steel | 30 | (4.6) | 304 SS |
| Turpentine | 300 | (148) | 20 | (3.1) | 304 SS | 25 | (3.8) | 304 SS |

Water

| | | | | | | | | |
|---------------|-----|-------|----|-------|---------------------|----|------|----------------|
| Clean | 212 | (100) | 60 | (9.3) | Incoloy® | 45 | (7) | Incoloy® 800 |
| Deionized | 212 | (100) | 60 | (9.3) | 316 SS (passivated) | 90 | (14) | Incoloy® 800 |
| Demineralized | 212 | (100) | 60 | (9.3) | 316 SS (passivated) | 90 | (14) | Incoloy® 800 |
| Potable | 212 | (100) | 60 | (9.3) | Incoloy® | 45 | (7) | Incoloy® 800 |
| Process | 212 | (100) | 48 | (9.3) | Incoloy® | | | Contact Watlow |

① Contact your Watlow representative.

③ Per API standards.

Reference Data

Tubular Elements and Assembly Selection Guide

Free Cross Sectional Area of WATROD and FIREBAR Circulation Heaters

Free cross sectional areas from the chart are in square feet. Calculations are based on:

- Flange 12 inches and under, pipes are schedule 40
- Flanges 14 inches and above, pipes are standard wall thickness 0.375 in. (9.5 mm)
- All WATROD heating elements are 0.475 in. (12 mm) diameter

| Circulation Heater Size in. | Free Cross Sectional Area in Square Feet (Number of Elements in Parenthesis) | | |
|-----------------------------|--|-------------|-------------|
| WATROD | | | |
| 2½ NPT | 0.044 (3) | | |
| 3 Flange | 0.044 (3) | 0.037 (6) | |
| 4 Flange | 0.074 (6) | | |
| 5 Flange | 0.124 (6) | 0.117 (9) | |
| 6 Flange | 0.172 (12) | 0.164 (15) | |
| 8 Flange | 0.303 (18) | 0.296 (21) | 0.288 (24) |
| 10 Flange | 0.481 (27) | 0.460 (36) | |
| 12 Flange | 0.697 (36) | 0.652 (54) | |
| 14 Flange | 0.848 (45) | 0.781 (72) | |
| 16 Flange | 1.091 (72) | 1.054 (87) | 1.017 (102) |
| 18 Flange | 1.372 (102) | 1.357 (108) | 1.342 (114) |
| 20 Flange | 1.748 (108) | 1.733 (114) | 1.704 (126) |
| FIREBAR | | | |
| 2½ NPT | 0.0417 (3) | | |
| 4 Flange | 0.0692 (6) | | |
| 6 Flange | 0.1540 (15) | | |

Reference Data

Tubular Elements and Assembly Selection Guide

Heat Transfer Oil Chart

| Heat Transfer Fluid | Recommended Max. Temperature °F (°C) | | Flammability Data °F (°C) | | | | | | Min. Velocity Thru Heater in Feet/second at W/in ² (M/second at W/cm ²) | | | | | | | | | |
|---------------------|--------------------------------------|-------|---------------------------|-------|-------------|---------|------------|---------|--|---------|--|--|--|--|--|--------|-----|--------|
| | Process | | Sheath | | Flash Point | | Fire Point | | Autoignition | | 8 | 16 | 23 | 30 | | | | |
| | F | (°C) | °F | (°C) | °F | (°C) | °F | (°C) | °F | (°C) | W/in ² (W/cm ²) | (1.2) W/in ² (W/cm ²) | (2.8) W/in ² (W/cm ²) | (3.6) W/in ² (W/cm ²) | (4.7) W/in ² (W/cm ²) | | | |
| Calflo HTF | 600 | (316) | 650 | (343) | 414 | (212) | 462 | (239) | 670 | (354) | 1.5 | (0.5) | 3.0 | (0.9) | 5.0 | (1.52) | 7.0 | (2.1) |
| Calflo AF | 550 | (288) | 600 | (316) | 400 | (204) | 437 | (225) | 650 | (343) | 1.5 | (0.5) | 3.0 | (0.9) | 5.0 | (1.52) | 7.0 | (2.1) |
| Dow therm® A | 750 | (399) | 835 | (446) | 255 | (124) | 275 | (135) | 1150 | (621) | 0.5 | (0.15) | 1.0 | (0.3) | 2.0 | (0.61) | 3.0 | (0.9) |
| Dow therm® G | 700 | (371) | 775 | (413) | 305 | (152) | 315 | (157) | 1150 | (621) | 0.7 | (0.2) | 1.5 | (0.5) | 2.5 | (0.75) | 3.5 | (1.1) |
| Dow therm® J | 575 | (302) | 650 | (343) | 145 | (63) | 155 | (68) | 806 | (430) | 1.0 | (0.3) | 2.0 | (0.61) | 3.0 | (0.9) | 4.5 | (1.37) |
| Dow therm® LF | 600 | (316) | 675 | (357) | 260 | (127) | 280 | (138) | 1020 | (549) | 0.7 | (0.2) | 1.5 | (0.5) | 2.5 | (1.75) | 3.5 | (1.1) |
| Dow therm® HT | 650 | (343) | 700 | (371) | no data | no data | no data | no data | no data | no data | 1.5 | (0.5) | 2.5 | (0.75) | 3.5 | (1.1) | 5.0 | (1.52) |
| Dow therm® Q | 625 | (329) | 700 | (371) | no data | no data | no data | no data | 773 | (412) | 0.7 | (0.2) | 1.5 | (0.5) | 2.5 | (0.75) | 3.5 | (1.1) |
| Marlotherm S | 662 | (350) | 698 | (370) | 374 | (190) | no data | no data | 932 | (500) | 1.5 | (0.5) | 3.0 | (0.9) | 5.0 | (1.52) | 7.0 | (2.1) |
| Mobiltherm 603 | 590 | (310) | 625 | (329) | 380 | (193) | no data | no data | no data | no data | 1.5 | (0.5) | 3.0 | (0.9) | 5.0 | (1.52) | 7.0 | (2.1) |
| Multitherm IG-2 | 600 | (316) | 650 | (343) | 440 | (227) | 500 | (260) | 700 | (371) | 0.8 | (0.24) | 1.7 | (0.52) | 2.3 | (0.7) | 3.0 | (0.9) |
| Multitherm PG-1 | 600 | (316) | 640 | (338) | 340 | (171) | 385 | (196) | 690 | (368) | 1.0 | (0.3) | 2.0 | (0.61) | 3.0 | (0.9) | 4.0 | (1.22) |
| Para Cymene | 600 | (316) | 650 | (343) | 117 | (47) | 152 | (72) | 817 | (438) | 0.7 | (0.2) | 1.5 | (0.5) | 2.5 | (0.75) | 3.5 | (1.1) |
| Syltherm 800 | 750 | (399) | 800 | (427) | 350 | (177) | 380 | (193) | 725 | (385) | 1.5 | (0.5) | 3.0 | (0.9) | 5.0 | (1.52) | 7.0 | (2.1) |
| Syltherm XLT | 500 | (260) | 550 | (288) | 116 | (47) | 130 | (54) | 662 | (350) | 1.5 | (0.5) | 2.5 | (0.75) | 4.0 | (1.22) | 5.0 | (1.52) |
| Texatherm | 600 | (316) | 640 | (338) | 430 | (221) | no data | no data | no data | no data | 2.0 | (0.61) | 4.0 | (1.22) | 6.0 | (1.83) | 8.0 | (2.4) |
| Thermia 33 | 600 | (316) | 650 | (343) | 455 | (235) | 495 | (257) | no data | no data | 1.5 | (0.5) | 3.0 | (0.9) | 5.0 | (1.52) | 7.0 | (2.1) |
| Therminol 44 | 400 | (204) | 475 | (246) | 405 | (207) | 438 | (228) | 705 | (374) | 1.0 | (0.3) | 2.0 | (0.61) | 3.0 | (0.9) | 4.0 | (1.22) |
| Therminol 55 | 550 | (288) | 605 | (318) | 350 | (177) | 410 | (210) | 675 | (357) | 1.5 | (0.5) | 2.5 | (0.75) | 3.5 | (1.1) | 5.0 | (1.52) |
| Therminol 59 | 600 | (316) | 650 | (343) | 302 | (150) | 335 | (168) | 770 | (410) | 1.5 | (0.5) | 2.5 | (0.75) | 3.5 | (1.1) | 5.0 | (1.52) |
| Therminol 60 | 620 | (327) | 655 | (346) | 310 | (154) | 320 | (160) | 835 | (448) | 1.5 | (0.5) | 3.0 | (0.9) | 5.0 | (1.52) | 7.0 | (2.1) |
| Therminol 68 | 650 | (343) | 705 | (374) | 350 | (177) | 380 | (183) | 705 | (374) | 1.5 | (0.5) | 2.5 | (0.75) | 3.0 | (0.9) | 4.5 | (1.37) |
| Therminol 75 | 750 | (399) | 805 | (429) | 390 | (199) | 440 | (227) | 1000 | (538) | 1.0 | (0.3) | 2.0 | (0.61) | 3.0 | (0.9) | 4.0 | (1.22) |
| Therminol LT | 600 | (316) | 650 | (343) | 134 | (57) | 150 | (66) | 805 | (429) | 1.5 | (0.5) | 2.5 | (0.75) | 4.0 | (1.22) | 5.0 | (1.52) |
| Therminol VP-1 | 750 | (399) | 800 | (427) | 255 | (124) | 280 | (127) | 1150 | (621) | 1.0 | (0.3) | 2.0 | (0.61) | 3.0 | (0.9) | 4.0 | (1.22) |
| U-Con 500 | 500 | (260) | 550 | (288) | 540 | (282) | 600 | (316) | 750 | (399) | 1.0 | (0.3) | 2.0 | (0.61) | 3.0 | (0.9) | 4.0 | (1.22) |